

elentek®

One Step Forward



TEKPRESS EVO



TEKPRESS PRO

INSTRUCTION MANUAL

CE



Risk of damaging the pressure assemblies and/or the plant.
Riesgo de daño al grupo de presión o a la instalación
Risque d'endommagement du groupe de pression ou de l'installation
Rischio di danno al gruppo di pressione o all'installazione
Gefahr der Beschädigung des Steuergerätes und der Druckleitungen und / oder der gesamten Anlage



Risk by electric shock
Riesgo por choque eléctrico.
Risque d'électrocution
Rischio di shock elettrico
Gefahr durch Stromschlag.



Risk for people and/or objects
Riesgo para personas y/o objetos
Risque physiques et/ou matériels
Rischio per persone e/o oggetti
Gefahr für Personen und / oder Objekte

A

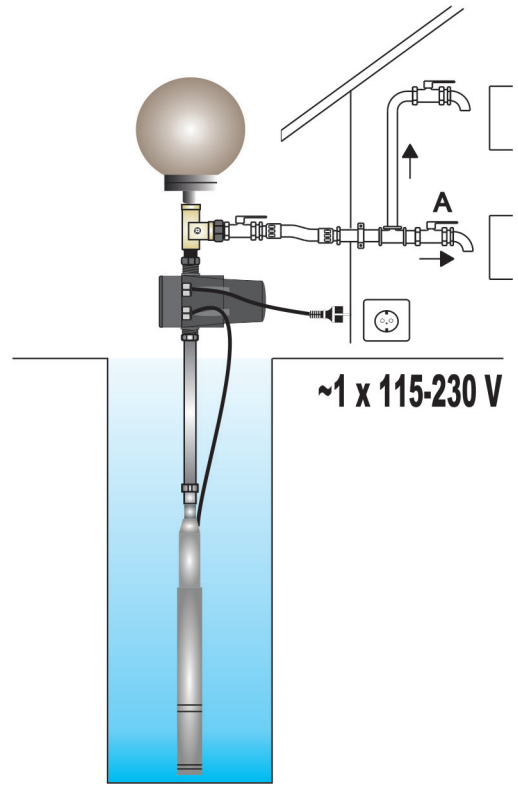
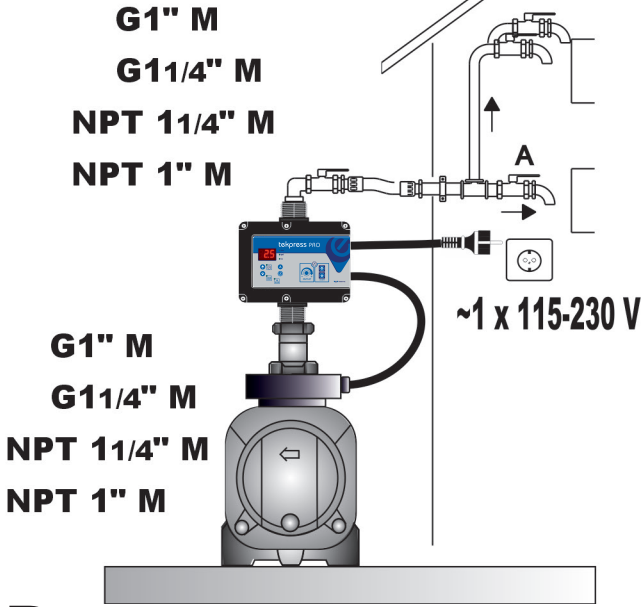

B

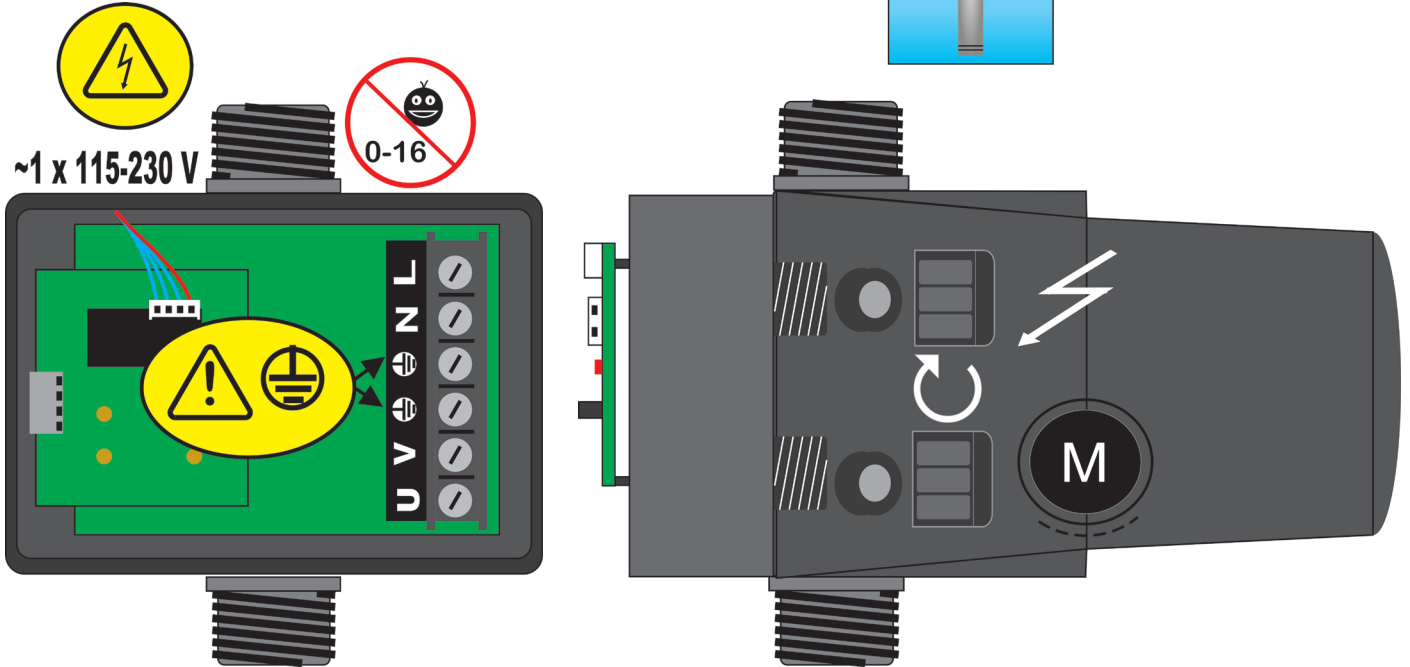

C



D

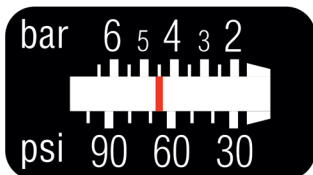

ENGLISH

GENERAL

Read carefully the instructions before installing this unit. Verify the technical characteristics of the motor in order to assure the compatibility with the device.

DESCRIPTION

• EPR - *Electronic Pressure Regulator* -

Is an electronic drive for single-phase pumps up to 2,2 kW (1~115-230V) with an innovative system of pressure reduction/regulation in order to maintain an steady outlet pressure. Therefore, in addition to the typical features of traditional electronic pump controllers: integrated non-return valve, flow sensor, accumulation membrane, pressure gauge, indicator led-lights, dry-run protection, automatic restore system (ART), ... it is adjusted and stabilized the output pressure, avoiding overloads and water hammer, ultimately, improving the comfort and durability of the installation.

• DPR - *Digital Pressure Regulator* -

Evolutes from EPR, adding to its features a digital display with instaneous indication of current consumption and outlet pressure since it houses current and pressure transducers inside. This device allows disassociating the regulation of the outlet pressure from the cut-in pressure to improve the elasticity of the system's hydraulic reserve, favoring the prolongation of inactive pauses and, consequently, reducing the number of starts of the electric pump. This independence from pressure regulation also allows operation with a minimum differential between the cut-in pressure (ON) and the outlet pressure (OUT). It also integrates alarm and function registers, as well as the possibility of adjusting multiple operating parameters such as automatic reset system, anti-flood function, start and stop delays, etc.

OPERATING CHARACTERISTICS

	EPR	DPR
Starting pressure	Depends on the adjusted outlet pressure. Table 1.	Adjustable from 0,5bar to 5,5bar. Table 2.
Outlet pressure	Adjustable from 2,5 bar to 6 bar by the rear allen screw. Figure 1 and 2.	Adjustable from 2,5 bar to 6 bar by the rear allen screw. Figure 1 and 2.
Outlet pressure reading	Manometer	Digital
Dry-running protection	Yes	Yes
Overcurrent protection	No	Yes
ART* Fuction	Yes	Yes
Manual start push-button	Yes	Yes
Control panel	LED indicator lights and ENTER push button	3-digit display, LED indicator lights and 4 push buttons (up and down arrows, amps and enter)
APR function*	Yes	Yes
Anti-flooding configuration.	No	Yes
Stand-by mode	No	Yes

*ART FUNCTION (Automatic Reset Test)

When the device has stopped the pump by the intervention of the dry-running protection system the ART tries, after 5 minutes, to re-start the pump in order to restore the water supply.

After this first attempt are performed consecutive attempts every 30 minutes.

In the DPR, this function can be activated in the ADVANCED MENU. It can also be set the number of attempts (1-48) and the span of the attempt (10-40 seconds).

*APR FUNCTION (Anti-blocking Periodic Routine)

After 72 hours without operation the pump is automatically started for 10 seconds in order to avoid rotor locking. In the DPR the display will show the message "APr" while the pump is operating. In the EPR the pump LED will be on during this operation.

TECHNICAL CHARACTERISTICS

- Rated motor power: 0,37-2,2KW
- Power supply: ~1 x 110-230Vac
- Frequency: 50/60Hz
- Max. current: 16A, cos fi ≥ 0.6
- Protection degree: IP65*
- Maximum water temperature: 50°C
- Maximum environment temperature: 60°C
- Outlet pressure: (±0.5 bar) 2,5-6 bar
- Starting pressure range:
 - DPR: 0,5 - 5,5 bar (factory setting 1,5 bar)
 - EPR: 1,0 - 4,5 bar. Table 1.
- Maximum operating pressure: 10 bar
- Hydraulic connection (types):
 - G 1" M
 - G 1" ¼ M
 - NPT 1" M
 - NPT 1" ¼ M
- Net weight (without cables): 2 kg

***Plugs and sockets built into the wiring of the device could modify the declared IP rating.**

HIDRAULIC INSTALLATION (diagram A)

 Before proceeding with hydraulic connection it is essential to prime the pump correctly. DPR or EPR must be installed in a vertical position (arrows in upward position), thus connecting the inlet opening directly to the pump outlet; and the outlet to the network. The following accessories are recommended: flexible with a disassembling link for network protection, protecting the set from possible flexion charges and vibrations, ball valve which permits the isolation of the pump from the net, a tap at the same level of the unit. See diagram A.

ELECTRIC CONNECTION (diagram B)

 The electric connection must be performed by qualified technicians in compliance with regulation of each country. Before doing manipulations inside the device, it must be disconnected from the electric supply. Wrong connection could spoil the electronic circuit.

The manufacturer declines all responsibility in damages caused by wrong connections.

Check if power supply is between 110-230V. If you have purchased the unit without cables follow diagram B. EPR and DPR devices have the same electric wiring diagram.

- Use cables type H07RN-F 3G1 or 3G1,5 with section enough to the power installed.
- Do the pump connection U, V and Ⓢ.
- Do the power supply connection L, N and Ⓢ.
- The earth conductor must be longer than the others. It will be the first one to be mounted during the assembly and the last one to be disconnected during the dismantling.

The earth conductors connections are compulsory!



CONTROL PANEL (diagram C)





The meanings of the different control panel elements are summarized on the following tables, where:

- O means lit LED light.
- ((O)) means LED flashing.





DPR - Digital Pressure Regulator -

DISPLAY	ACTION
OPERATION MODE	Is showed on screen instantaneous pressure or instantaneous current consumption.
ADJUSTMENT MODE	Is displayed on screen the adjusted start pressure. Is displayed the adjusted rated current.
ALARM MODE	Is displayed the alarm code.
STAND-BY MODE	Are displayed 3 flashing dots.
BASIC CONFIG.	Is displayed the sequence of basic configuration parameters.
ADVANCED CONFIG.	Is displayed the sequence of advanced configuration parameters.

LEDS	DISPLAY	ACTION
O bar	O	Is displayed on screen the instantaneous pressure in bar
	((O))	Pump ON and is displayed on screen the instantaneous pressure in bar
O psi	O	Is displayed on screen the instantaneous pressure in psi
	((O))	Pump ON and is displayed on screen the instantaneous pressure in psi
O A	O	Is displayed on screen the instantaneous current consumption in Ampere units
	((O))	Pump ON and is displayed on screen the instantaneous current consumption in Ampere units
	O	Is displayed the start pressure
	((O))	Adjusting start pressure
	O	It indicates positive flow
	O	Rated dry-running or overload alarms
ALARM 	((O))	Dry-running alarm performing ART or overload alarm performing any of the 4 restore attempts

P-BUTTON	TOUCH	ACTION
	click!	From state ON: any alarm is restored. From state OFF: system changes to STATE ON, the pump starts. From any configuration MENU: the parameter value is accepted.
	HOLD DOWN	From state ON: unit OFF, relay disconnection. From state OFF: the pump starts and keeps operating until the push-button is released.
	click!	Pstart is displayed on the screen for 3 seconds.
	click!	Increase the programming value.
UP ARROW	3"	Pstart adjustment mode.
	click!	Decrease the programming value.
	click!	Decrease the programming value.
	click!	Is displayed on the screen instantaneous current consumption. If it is already displayed then we switch to instantaneous pressure view.
AMPERE 	3"	Rated current adjustment.

EPR - Electronic Pressure Regulator -

LEDS	DISPLAY	ACTION
	O	It indicates the device is connected to the power supply.
	O	Rated dry-running or overload alarms
ALARM 	((O))	Dry-running alarm performing ART or overload alarm performing any of the 4 restore attempts
	O	It indicates the pump is working.
PUMP 	O	It indicates positive flow.
FLOW 	O	It indicates positive flow.

P-BUTTON	TOUCH	ACTION
	click!	Any alarm is restored.
	HOLD DOWN	The pump starts and keeps operating until the push-button is released.

STARTUP





 Before starting the device please read the previous sections, especially "Hydraulic Installation" and "Electrical connection".

Follow next steps:

1. Start the device. Connect to the power supply and press ENTER  in the DPR model. Connect to the power supply in the EPR model.





2. (Only DPR)

Set the pump rated current intensity value:

- Press  during 3 seconds.
- The current intensity value is displayed on screen and LED A is flashing (factory setting 16A).
- By mean of  and  is adjusted the rated current reflected in the characteristics plate of the motor. See Note 1.
- Press  for validation.

3. (Only DPR)

Set the cut-in (start) pressure:

- Press  during 3 seconds.
- The start pressure value is displayed on screen and LED START is flashing.
- By mean of  and  is adjusted the start pressure from 0,5 to 5,5 bar.
- Press  for validation.

4. Set the maximum pressure of the installation:

- Open a tap.
- Take the provided allen key.

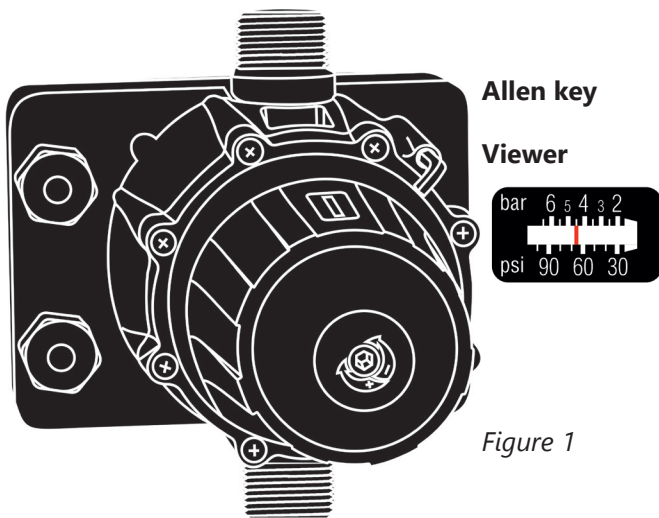

Figure 1

- Turn the regulation screw clockwise to increase the outlet pressure and anticlockwise to decrease it (factory setting 3 bar). Look at the working pressure viewer (Fig. D) while turning the screw to have a first approximation of the outlet pressure setting.

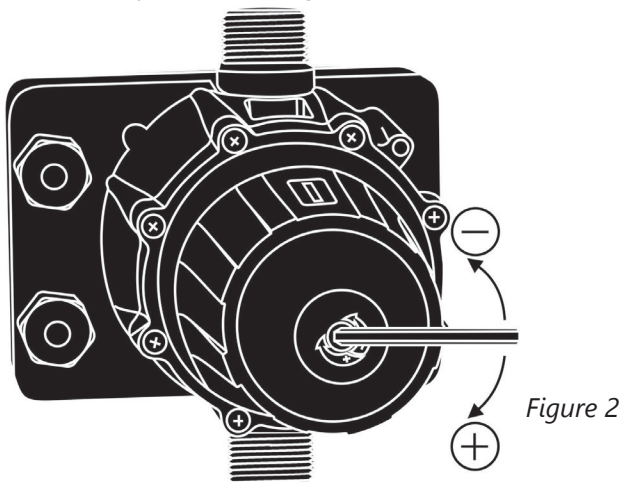

Figure 2

- Close the tap and do the final adjustment looking at the manometer (EPR) or the display (DPR).

- The regulated pressure should be at least 1bar less than the maximum pressure of the pump.

EPR pressure diagram:

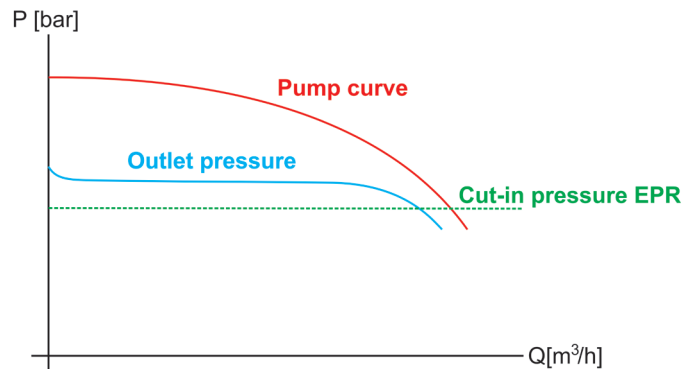

Table 1:

OUTLET PRESSURE	CUT IN PRESSURE	MINIMUM PUMP PRESSURE	MAXIMUM WATER COLUMN
2 bar	1±0,5 bar	3 bar	4 m
3 bar	1,8±0,5 bar	4 bar	12 m
4 bar	2,5±0,5 bar	5 bar	18 m
5 bar	3,5±0,5 bar	6 bar	25 m
6 bar	4,5±0,5 bar	7 bar	30 m

DPR pressure diagram

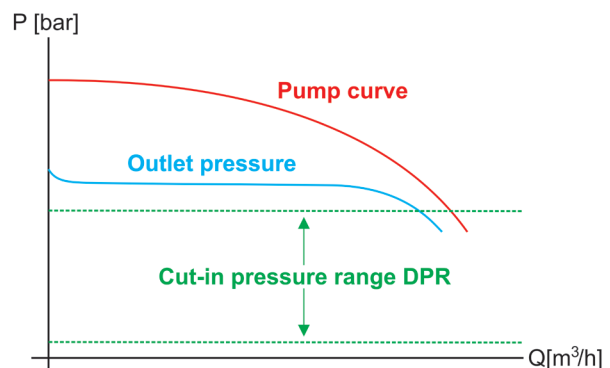







Table 2:

OUTLET PRESSURE	CUT IN PRESSURE	MINIMUM PUMP PRESSURE	MAXIMUM WATER COLUMN
2 bar	0,5-1,5 bar	3 bar	3-8 m
3 bar	0,5-2,5 bar	4 bar	3-15 m
4 bar	0,5-3,5 bar	5 bar	3-20 m
5 bar	0,5-4,5 bar	6 bar	3-30 m
6 bar	0,5-5,5 bar	7 bar	3-40 m

5. The unit EPR is ready to operate but the unit DPR has more optional adjustments that can be set through basic and advanced MENUS. See the next chapter.







Note 1: it is important to introduce exactly the rated current specified on the nameplate of the pump. If a new pump is installed this process should be repeated.

BASIC MENU + (diagram C)

- Press simultaneously  +  during 5 seconds.
- By mean of  or  the values can be changed.
- Press  for validation.
- This is the parameters sequence:

TYPE	SYSTEM REACTION	FACTORY SETTING
bar psi	We can select the pressure units displayed between bar and psi.	bar

ADVANCED MENU + +



- Press simultaneously  +  +  during 5 seconds.
- By mean of  or  the values can be changed.
- Press  for validation.
- The parameters sequence is:

SCREEN	SYSTEM REACTION	FAC-TORY SET-TING
Ar0 Ar1	Activation of the automatic restore system ART (Ar1) o disable (Ar0).	Ar1
n01 n48	In case of enabled ART, it can be set the number of restore at-tempts, between 1 and 48.	48
t10 t40	It can be set the span of the at-tempt between 10 and 40 seconds.	15"
Sb0 Sb1	Stand-by disabled (Sb0) or enabled (Sb1)	0
H00 H99	Anti-flooding configuration. If activated, it stops the pump after programmed time (in hours) of continuous operation. Disabled (H00), 1 hour (H01) ... 24 hours (H24).	H00
rs0 rs1	Restore factory settings (rs1)	rs0



PRESSURE SENSOR CALIBRATION

In case of wrong lecture of the pressure sensor it can be adjusted again. For the pressure sensor calibration is necessary to have a pressure gauge in the installation. Proceed following next steps:

ZERO REGULATION

1. Open the taps living the hydraulic net without pressure.
2. Press simultaneously the buttons  and  until the display show 0.0 flashing.
3. Press  to validate.

FULL SCALE

1. Set the outlet pressure equal to the maximum pressure of the pump. In case of using a pump with higher pressure than 6 bar, set the outlet pressure to 6 bar. (Go to the point 4 of the STARTUP to remember how to set the outlet pressure)
2. Start the device and wait until it stops the pump.
3. Press simultaneously the buttons  and  till the display flashes with a figure.
4. Adjust the pressure with the arrows push-buttons to get the pressure desired.
5. Press  to validate.

Examples:

MAXIMUM PUMP PRESSURE	OUTLET PRESSURE	ADJUSTED FULL SCALE
4 bar	4 bar	4 bar
8 bar	6 bar	6 bar

Remark: pressure sensor decalibration should not be a normal event. If it is frequently repeated contact the technical service.

WARNINGS AND ALARMS

DPR

COD.	ALARM	DESCRIPTION	SYSTEM REACTION
A01	○ ((○))	DRY RUNNING	When is detected a dry-run operation the pump is automatically stopped. By mean of ENTER the normal operation can be manually restored. After the activation of the dry-running alarm if the Automatic system reset (ART) is enabled, a first attempt at 5 minutes and then an attempt every 30 minutes for 24 hours is performed in order to restore the normal operation. This alarm can also be reset manually with the ENTER push-button. If the alarm persists after 24 h we find a definitive alarm.
A02	○ ((○))	OVERLOAD	Overcurrent alarm is activated when the nominal pump current is exceeded. 4 automatic reset attempts prior to the final alarm are performed. Normal operation can also be restored manually by pressing ENTER.
A05	○	DAMAGED PRES-SURE TRANSMITTER	CONTACT WITH YOUR SUPPLIER
A30	○	ANTI-FLOODING	FLOOD protection has been activated because the pump has been running continuously for a period of time equal to the limit set in the ADVANCED MENU. It is manually reset by pressing ENTER.

EPR

ALARM	DESCRIPTION	SYSTEM REACTION
○ ((○))	DRY RUNNING	When is detected a dry-run operation the pump is automatically stopped. By mean of ENTER the normal operation can be manually restored. After the activation of the dry-running alarm if the Automatic system reset (ART) is enabled, a first attempt at 5 minutes and then an attempt every 30 minutes for 24 hours is performed in order to restore the normal operation. This alarm can also be reset manually with the ENTER push-button. If the alarm persists after 24 h we find a definitive alarm.

CLASSIFICATION AND TYPE

According to IEC 60730-1 and EN 60730-1 this unit is a control sensor device, electronic, independent assembly, with action type 1B (microdisconnection). Operating value: I <20% I learned. Pollution degree 2 (clean environment) or flow >2,5 l/min. Rated impulse voltage: cat II / 2500V. Temperatures for ball test: enclosure (75) and PCB (125).

CONDIZIONI GENERALI / GENERAL CONDITIONS

PRESCRIZIONI GENERALI DEL QUADRO ELETTRICO

Il quadro elettrico fornito è progettato per il comando di una o più utenze monofase/trifase o per la tele-commutazione rete/gruppo.

Installare l'apparecchio lontano da fonti di calore e in luogo asciutto e riparato rispettando il grado di protezione (IP) dichiarato.

Si raccomanda l'installazione di un apposito dispositivo di sicurezza atto a proteggere la linea di alimentazione del quadro nel rispetto delle norme elettriche vigenti.

Prima di qualsiasi operazione di installazione o manutenzione assicurarsi di aver scollegato la tensione di alimentazione elettrica.

L'apertura del quadro elettrico è consentita solo a personale autorizzato e qualificato. In caso di necessità sostituire i componenti con altri di pari caratteristiche.

L'ufficio tecnico di ELENTEK S.r.l. è a Vostra disposizione in caso di dubbi e per tutti i chiarimenti tecnici che si rendessero necessari alla corretta installazione e utilizzo dell'apparecchiatura acquistata.

GARANZIA E ASSISTENZA

I prodotti sono coperti da una garanzia di 12 mesi dalla data di consegna al cliente finale, comprovata con DDT (documento di trasporto) o fattura.

La garanzia non può superare in ogni caso i 18 mesi dalla data di spedizione da ELENTEK S.r.l. e copre i difetti di costruzione limitandosi alla sostituzione o riparazione dei pezzi difettosi.

Il prodotto perde la copertura di garanzia nei seguenti casi:

- Manomissione/modifica non autorizzata dell'apparecchio elettrico
- Installazione non corretta o inosservanza del manuale d'uso
- Guasto causato da protezione inadeguata e/o da collegamento/installazione errato/a
- Guasto causato da sovraccarico oltre i limiti di targa
- Normale deterioramento dei componenti
- Cause accidentali o calamità naturali quali ad esempio allagamenti, fulmini, incendi etc.

Il materiale difettoso dovrà essere ritornato a Elentek S.r.l. in Porto Franco.

ELENTEK S.r.l. si riserva il giudizio insindacabile sulla causa del guasto e sull'eventuale copertura dello stesso da garanzia. La garanzia comprende esclusivamente il ripristino delle caratteristiche e funzionalità del prodotto e non include eventuali danni a cose o persone.

Per ulteriori informazioni si rimanda alla documentazione contrattuale di vendita.

SMALTIMENTO

Informazioni agli utenti ai sensi dell'art. 26 del decreto legislativo 14 marzo 2014, n.59 "Attuazione della Direttiva 2012/19/UE sui rifiuti di apparecchiature elettriche ed elettroniche (RAEE)".

L'utente ha l'obbligo di non smaltire i Rifiuti di Apparecchiature Elettriche ed Elettroniche (RAEE) come rifiuti urbani misti ed ha quindi l'obbligo di effettuare la raccolta differenziata.

L'utente dovrà, pertanto, conferire l'apparecchiatura giunta a fine vita a soggetti abilitati alla loro manipolazione/trattamento (compresi i distributori nel caso dell'acquisto di un nuovo apparecchio) o agli idonei centri di raccolta differenziata per i rifiuti elettronici ed elettrotecnici, nonché contattare l'azienda produttrice che provvederà a fornire idonee istruzioni in caso di necessità.

L'adeguata raccolta differenziata per l'avvio successivo dell'apparecchiatura dismessa al riciclaggio, al trattamento e allo smaltimento ambientale compatibile contribuisce ad evitare possibili effetti negativi sull'ambiente e sulla salute e favorisce il riciclo/recupero dei materiali di cui è composta l'apparecchiatura. L'uso improprio delle apparecchiature o parti di esse può provocare danni alla salute umana.

Il simbolo del cassonetto barrato riportato sull'apparecchiatura indica che il prodotto alla fine della propria vita utile deve essere raccolto separatamente dagli altri rifiuti, in modo differenziato dai comuni rifiuti urbani.

Lo smaltimento abusivo del prodotto da parte dell'utente comporta l'applicazione delle sanzioni amministrative di cui al D.Lgs. 152/2006 (Artt. 255-256-256bis-259-260).

Quanto qui riportato può essere soggetto ad adeguamenti ed aggiornamenti normativi da parte dell'Organo Legislatore.

PRESCRIPTION OF THE CONTROL PANEL

The control panel supplied is projected for the control of one or more single-phase or three-phase motors or for the mains/generator transfer switch.

Do not install the device near heating sources and/or in wet places. Respect the IP degree indicated.

Elentek recommends to install a special safety device in order to protect the mains supply line in respect of the electrical regulations in use.

Prior to any other operation of installation or maintenance please make sure that mains supply is disconnected.

Authorized and qualified personnel only is allowed to open the control panel. In case of need please replace the components with other with same features.

Elentek's technical department is at your disposal in case of doubts and for all necessary information for the correct installation and use of the purchased device.

WARRANTY AND E ASSISTENZA

The product is covered by 12 months warranty from the delivery date to the final customer, proved by delivery note or invoice.

Warranty cannot exceed in any case 18 months from the delivery by Elentek and covers manufacturing faults limited to the replacement or fixing the faulty pieces.

Warranty is not applicable in the following cases:

- Tampering/modification of the electrical device not authorized
- Incorrect installation or inobservance of the user manual
- Damage caused by inadequate protection and/or by wrong connection/installation
- Damage caused by overload over the declared data
- Regular deterioration of the components
- Accidental causes or natural disasters such as floodings, lightnings, fires etc.

The faulty material has to be sent back to ELENTEK S.r.l. at customer's charge.

ELENTEK S.r.l. has the right to judge the cause of the fault and the eventual warranty application.

Warranty includes the restoration of the operation and features of the product only and does not include eventual damages to objects or persons.

For further information please refer to the sale documents.

DISPOSAL

Information to users pursuant to art. 26 of Legislative Decree 14 March 2014, No. 59 "Implementation of Directive 2012/19 / EU on waste electrical and electronic equipment (WEEE)".

The user is obliged not to dispose of waste of Electrical and Electronic Equipment (WEEE) as mixed urban waste and therefore has the obligation to carry out separate collection.

The user must give the equipment at the end of its life to subjects authorized to their handling / treatment (including distributors in the case of the purchase of a new appliance) or to the appropriate separate collection centers for electronic and electro-technical waste, as well as contact the manufacturer that will provide suitable instructions in case of need.

The adequate differentiated collection for the subsequent start-up of the decommissioned equipment for recycling, treatment and compatible environmental disposal contributes to avoiding possible negative effects on the environment and on health and favors the recycling / recovery of the materials of which the compound is composed. equipment. Improper use of the equipment or parts of it can cause damage to human health.

The symbol of the crossed-out bin indicated on the equipment indicates that the product at the end of its useful life must be collected separately from other waste, in a different way from common urban waste.

Unauthorized disposal of the product by the user entails the application of administrative sanctions pursuant to Legislative Decree 152/2006 (Articles 255-256-256bis-259-260).

The information given here may be subject to adjustments and regulatory updates by the Legislative Organ.

DICHIARAZIONE DI CONFORMITÀ / CONFORMITY DECLARATION

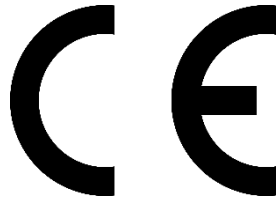

Nome del prodotto / Product's name:

- **TEKPRESS EVO**
- **TEKPRESS PRO**

NORMATIVE

ELENTEK S.r.l. dichiara che i prodotti di propria produzione e distribuzione sono conformi alle seguenti direttive della Comunità Europea:

- ✓ *Direttiva RoHS II 2011 65/EC*
- ✓ *Direttiva (RAEE) 2012/19/UE*
- ✓ *Direttiva europea Bassa Tensione 2014/35 UE*
- ✓ *Compatibilità elettromagnetica 2014/30 UE e successive modifiche e conformi alle seguenti norme tecniche:*
 - EN 60730-1
 - EN 60730-2-6
 - EN 61000-6-1
 - EN 61000-6-3
 - IEC-60730-1
 - IEC-60730-2-6

NORMATIVE

ELENTEK S.r.l. declares that the products manufactured and distributed are in compliance with the following European regulations:

- ✓ *Directive RoHS II 2011 65/EC*
- ✓ *Directive (RAEE) 2012/19/UE*
- ✓ *Low voltage European Directive 2014/35 UE*
- ✓ *Electromagnetic compatibility 2014/30 UE and conform with technical regulations:*
 - EN 60730-1
 - EN 60730-2-6
 - EN 61000-6-1
 - EN 61000-6-3
 - IEC-60730-1
 - IEC-60730-2-6

LEGALE RAPPRESENTANTE

Michele Borgato

ELENTEK SRL SOCIETÀ UNIPERSONALE

Via A. Meucci 5/11 - 35028 Piove di Sacco (PD) - ITALIA

Tel. +39 049 9730367 - Fax +39 049 9731063

www.elentek.com - info@elentek.com

P.IVA 04534630282



CONDIZIONI GENERALI / GENERAL CONDITIONS

PRESCRIZIONI GENERALI DEL QUADRO ELETTRICO

Il quadro elettrico fornito è progettato per il comando di una o più utenze monofase/trifase o per la tele-commutazione rete/gruppo.

Installare l'apparecchio lontano da fonti di calore e in luogo asciutto e riparato rispettando il grado di protezione (IP) dichiarato.

Si raccomanda l'installazione di un apposito dispositivo di sicurezza atto a proteggere la linea di alimentazione del quadro nel rispetto delle norme elettriche vigenti.

Prima di qualsiasi operazione di installazione o manutenzione assicurarsi di aver scollegato la tensione di alimentazione elettrica.

L'apertura del quadro elettrico è consentita solo a personale autorizzato e qualificato. In caso di necessità sostituire i componenti con altri di pari caratteristiche.

L'ufficio tecnico di ELENTEK S.r.l. è a Vostra disposizione in caso di dubbi e per tutti i chiarimenti tecnici che si rendessero necessari alla corretta installazione e utilizzo dell'apparecchiatura acquistata.

GARANZIA E ASSISTENZA

I prodotti sono coperti da una garanzia di 12 mesi dalla data di consegna al cliente finale, comprovata con DDT (documento di trasporto) o fattura.

La garanzia non può superare in ogni caso i 18 mesi dalla data di spedizione da ELENTEK S.r.l. e copre i difetti di costruzione limitandosi alla sostituzione o riparazione dei pezzi difettosi.

Il prodotto perde la copertura di garanzia nei seguenti casi:

- Manomissione/modifica non autorizzata dell'apparecchio elettrico
- Installazione non corretta o inosservanza del manuale d'uso
- Guasto causato da protezione inadeguata e/o da collegamento/installazione errato/a
- Guasto causato da sovraccarico oltre i limiti di targa
- Normale deterioramento dei componenti
- Cause accidentali o calamità naturali quali ad esempio allagamenti, fulmini, incendi etc.

Il materiale difettoso dovrà essere ritornato a Elentek S.r.l. in Porto Franco.

ELENTEK S.r.l. si riserva il giudizio insindacabile sulla causa del guasto e sull'eventuale copertura dello stesso da garanzia. La garanzia comprende esclusivamente il ripristino delle caratteristiche e funzionalità del prodotto e non include eventuali danni a cose o persone.

Per ulteriori informazioni si rimanda alla documentazione contrattuale di vendita.

SMALTIMENTO

Informazioni agli utenti ai sensi dell'art. 26 del decreto legislativo 14 marzo 2014, n.59 "Attuazione della Direttiva 2012/19/UE sui rifiuti di apparecchiature elettriche ed elettroniche (RAEE)".

L'utente ha l'obbligo di non smaltire i Rifiuti di Apparecchiature Elettriche ed Elettroniche (RAEE) come rifiuti urbani misti ed ha quindi l'obbligo di effettuare la raccolta differenziata.

L'utente dovrà, pertanto, conferire l'apparecchiatura giunta a fine vita a soggetti abilitati alla loro manipolazione/trattamento (compresi i distributori nel caso dell'acquisto di un nuovo apparecchio) o agli idonei centri di raccolta differenziata per i rifiuti elettronici ed elettrotecnici, nonché contattare l'azienda produttrice che provvederà a fornire idonee istruzioni in caso di necessità.

L'adeguata raccolta differenziata per l'avvio successivo dell'apparecchiatura dismessa al riciclaggio, al trattamento e allo smaltimento ambientale compatibile contribuisce ad evitare possibili effetti negativi sull'ambiente e sulla salute e favorisce il riciclo/recupero dei materiali di cui è composta l'apparecchiatura. L'uso improprio delle apparecchiature o parti di esse può provocare danni alla salute umana.

Il simbolo del cassonetto barrato riportato sull'apparecchiatura indica che il prodotto alla fine della propria vita utile deve essere raccolto separatamente dagli altri rifiuti, in modo differenziato dai comuni rifiuti urbani.

Lo smaltimento abusivo del prodotto da parte dell'utente comporta l'applicazione delle sanzioni amministrative di cui al D.Lgs. 152/2006 (Artt. 255-256-256bis-259-260).

Quanto qui riportato può essere soggetto ad adeguamenti ed aggiornamenti normativi da parte dell'Organo Legislatore.

PRESCRIPTION OF THE CONTROL PANEL

The control panel supplied is projected for the control of one or more single-phase or three-phase motors or for the mains/generator transfer switch.

Do not install the device near heating sources and/or in wet places. Respect the IP degree indicated.

Elentek recommends to install a special safety device in order to protect the mains supply line in respect of the electrical regulations in use.

Prior to any other operation of installation or maintenance please make sure that mains supply is disconnected.

Authorized and qualified personnel only is allowed to open the control panel. In case of need please replace the components with other with same features.

Elentek's technical department is at your disposal in case of doubts and for all necessary information for the correct installation and use of the purchased device.

WARRANTY AND E ASSISTENZA

The product is covered by 12 months warranty from the delivery date to the final customer, proved by delivery note or invoice.

Warranty cannot exceed in any case 18 months from the delivery by Elentek and covers manufacturing faults limited to the replacement or fixing the faulty pieces.

Warranty is not applicable in the following cases:

- Tampering/modification of the electrical device not authorized
- Incorrect installation or inobservance of the user manual
- Damage caused by inadequate protection and/or by wrong connection/installation
- Damage caused by overload over the declared data
- Regular deterioration of the components
- Accidental causes or natural disasters such as floodings, lightnings, fires etc.

The faulty material has to be sent back to ELENTEK S.r.l. at customer's charge.

ELENTEK S.r.l. has the right to judge the cause of the fault and the eventual warranty application.

Warranty includes the restoration of the operation and features of the product only and does not include eventual damages to objects or persons.

For further information please refer to the sale documents.

DISPOSAL

Information to users pursuant to art. 26 of Legislative Decree 14 March 2014, No. 59 "Implementation of Directive 2012/19 / EU on waste electrical and electronic equipment (WEEE)".

The user is obliged not to dispose of waste of Electrical and Electronic Equipment (WEEE) as mixed urban waste and therefore has the obligation to carry out separate collection.

The user must give the equipment at the end of its life to subjects authorized to their handling / treatment (including distributors in the case of the purchase of a new appliance) or to the appropriate separate collection centers for electronic and electro-technical waste, as well as contact the manufacturer that will provide suitable instructions in case of need.

The adequate differentiated collection for the subsequent start-up of the decommissioned equipment for recycling, treatment and compatible environmental disposal contributes to avoiding possible negative effects on the environment and on health and favors the recycling / recovery of the materials of which the compound is composed. equipment. Improper use of the equipment or parts of it can cause damage to human health.

The symbol of the crossed-out bin indicated on the equipment indicates that the product at the end of its useful life must be collected separately from other waste, in a different way from common urban waste.

Unauthorized disposal of the product by the user entails the application of administrative sanctions pursuant to Legislative Decree 152/2006 (Articles 255-256-256bis-259-260).

The information given here may be subject to adjustments and regulatory updates by the Legislative Organ.

DICHIARAZIONE DI CONFORMITÀ / CONFORMITY DECLARATION

UK CA

Nome del prodotto / Product's name:

- **TEKPRESS EVO**
- **TEKPRESS PRO**

NORMATIVE

ELENTEK S.r.l. dichiara che i prodotti di propria produzione e distribuzione sono conformi alle seguenti direttive della Comunità Europea:

- ✓ *Direttiva RoHS II 2011 65/EC*
- ✓ *Direttiva (RAEE) 2012/19/UE*
- ✓ *Direttiva europea Bassa Tensione 2014/35 UE*
- ✓ *Compatibilità elettromagnetica 2014/30 UE e successive modifiche e conformi alle seguenti norme tecniche:*
 - BS EN 60730-1
 - BS EN 60730-2-6
 - BS EN 61000-6-1
 - BS EN 61000-6-3
 - BS IEC-60730-1
 - BS IEC-60730-2-6

NORMATIVE

ELENTEK S.r.l. declares that the products manufactured and distributed are in compliance with the following European regulations:

- ✓ *Directive RoHS II 2011 65/EC*
- ✓ *Directive (RAEE) 2012/19/UE*
- ✓ *Low voltage European Directive 2014/35 UE*
- ✓ *Electromagnetic compatibility 2014/30 UE and conform with technical regulations:*
 - BS EN 60730-1
 - BS EN 60730-2-6
 - BS EN 61000-6-1
 - BS EN 61000-6-3
 - BS IEC-60730-1
 - BS IEC-60730-2-6

LEGALE RAPPRESENTANTE

Michele Borgato



ELENTEK SRL SOCIETÀ UNIPERSONALE

Via A. Meucci 5/11 - 35028 Piove di Sacco (PD) - ITALIA

Tel. +39 049 9730367 - Fax +39 049 9731063

www.elentek.com - info@elentek.com

P.IVA 04534630282



NOTE

ELENTEK SRL SOCIETÀ UNIPERSONALE

Via A. Meucci 5/11 - 35028 Piove di Sacco (PD) - ITALIA

Tel. +39 049 9730367 - Fax +39 049 9731063

www.elentek.com - info@elentek.com

P.IVA 04534630282

Cod. MQ 0046 UK

Rev. 00

Em. 11.2023